



Service Partner  
to Humanity



**PARMAR METALS PVT. LTD.**



### Solar Structures

Parmar Metal Pvt Limited is a Rajkot based company, with its manufacturing facility at Rajkot District (Gujrat).

**Parmar Metals Pvt. Ltd.** is engaged in the manufacture and supply of Solar Structures Sections for various applications such as: Solar Structures – Purlins, Struts, Bracing Channels, Rafters, Post's, etc.

Designed as per the MNRE and IS norms, our products are of advanced quality. Designed to withstand wind load of 47 m/s as per IS standards, our products are resilient and have a minimum service life of 35 years.

Based on the project locations, our products are hot dip galvanized to a thickness of 80 to 120 microns.

### Solar PV structures

We offer wide range of products and services for solar structures for photovoltaic (PV)

Roll forming of solar structure sections thickness ranging from 1.25mm thick to 6.0mm thick

Manufacture of sections with post forming operations like, punching, slotting & notching

Fabrication of solar mounting structures as per customer's requirement.

Hot dip galvanizing of solar mounting structures as per customer's requirement.

### Solar Panel Mounting Service. (In-house facilities)

- Mechanical Tool Design
- Structure Design
- Coil Slitting & Punching
- Roll Forming
- Online Punching
- Hot Dip Galvanizing

### Cold Forming Process

- Slitted Longitudinally to the Customized width.
- Tools are designed.
- Strip of Coil Passes through Series of Rollers at Room Temperature to Get the Desired Shape & Length.
- Punching is done as per the Requirement.

### Raw Material

- Hot Rolled
- Width - 70 to 400 mm
- Thickness - 2 to 6 mm
- Grade - IS 2062, ISI 078, Fe 410, Fe 510
- Galvanizing - 550 gsm/m<sup>2</sup>

### Our Product Profile:

- Solar power plant structures
- Profiles for solar projects
- Roll forming profiles for solar projects
- H beam bars for solar projects
- Steel profiles for solar projects
- Solar profiles for solar projects
- Module mounting structure for solar projects
- Cold rolled structure for solar project
- Pre-galvanized structures for solar projects.
- Solar panel support structures.
- Solar parking structures
- Solar support structures
- Solar Structures
- Solar mounting structures
- Solar panel mounts,
- Solar mounting rails,
- Solar Profiles.

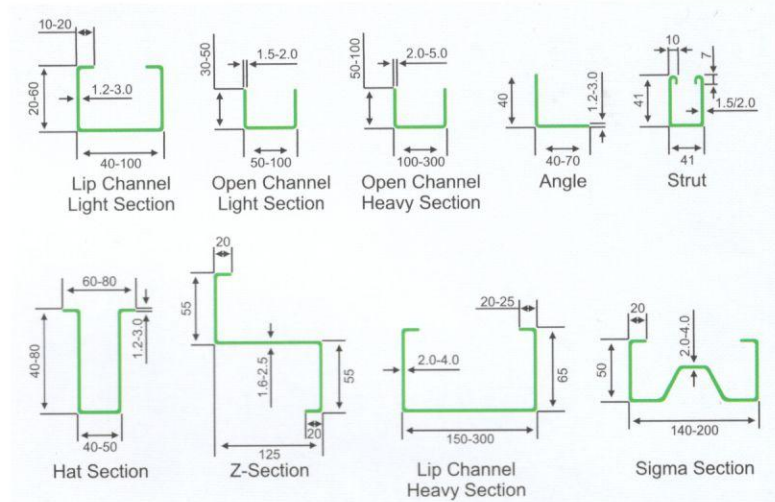
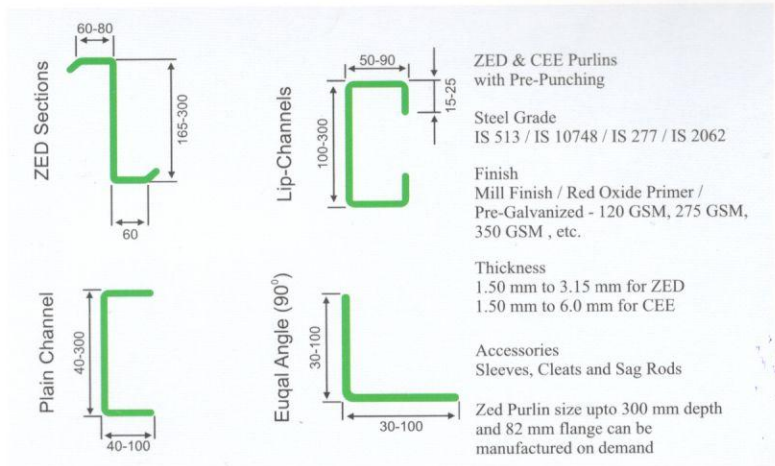



We are manufacturing solar panel mounting structure as per client requirements, we have very efficient design and manufacturing team to develop structure with high strength and easy to install. we make structure of material MS and aluminum.

At PMPL, we can provide the following solutions as per project requirements.

- Fixed type module mounting structures.
- Seasonal tilt adjustable module mounting structures.
- Single axis daily tracking structures.

### ▶ Solar Panel Support Structures (for Solar Power Projects)

With more and more awareness being generated about solar energy in our country, the demand for Solar panel support structures has also been constantly on the rise. PMPL manufactures these solar panel support structures in compliance with top quality international standards to give long lasting structures for these projects.

### ▶ Solar Module Mounting Structure

These are module mounting structures where Solar Panels are mounted. They support Solar Models from the roof. Being important structural elements, they must be manufactured exactly to specification. These structures are as important as Modules.

These structures are light in weight and durable as they are designed to ensure optimal Weight to Walt ratio.

### ▶ Module Mounting Structure

These easy to install structures provide an excellent solution to rural properties as they can be used on mountainous and rough terrain. Our ground based module mounting structures can be quickly delivered and are easy to install. These durable structures are an ideal solution for rural properties as they can be used to mount Photovoltaic panels on mountainous and rough terrain.

### ▶ Applications

- Roof Top Structures
- Ground Mounted Structures

### ▶ Advantages

- Very high strength-to-weight ratio; high strength, low cost.
- Significantly reduces installation time.
- No site drilling or cutting required.
- Maintenance-free owing to application of proper surface finish.
- Factory-finished, cut to exact lengths with pre-punched holes to avoid time and material wastage.
- Accessories like, connecting plates, angles splicing plates supplied along with main structure

### ▶ Ground Based Module Mounting Structure

At PMPL, we offer end-to-end solutions for ground based module mounting structures for solar installations, from design and fabrication to galvanization.

### ▶ Roof Mounted Structures

In a world of escalating real estate prices, ground space is at a premium. PMPL Roof mounted structures therefore are the perfect solution for urban environments. Our products are specifically designed to be lightweight to protect the underlying roof structure.

These easy to install structures are economical and are designed to withstand higher load and extreme conditions.

Standardised and modular designs allow for maximum utilisation of roof space. Our design ensures minimum drilling to avoid roof leakage.

With flexibility in product assembly, numerous layout options and advancements in structural engineering, we can design and install products with optimal usage of space, given module size and energy needs.

We supply module mounting structures for both flat roofs and sloped roofs (tile/sheet roofs).

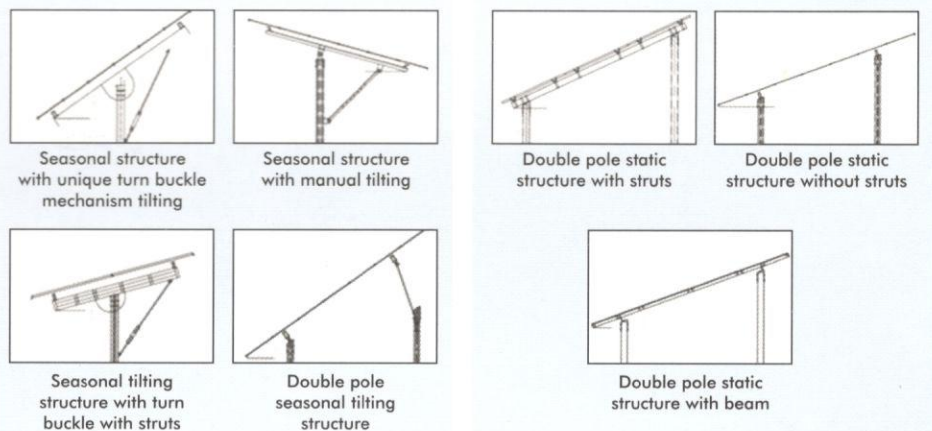
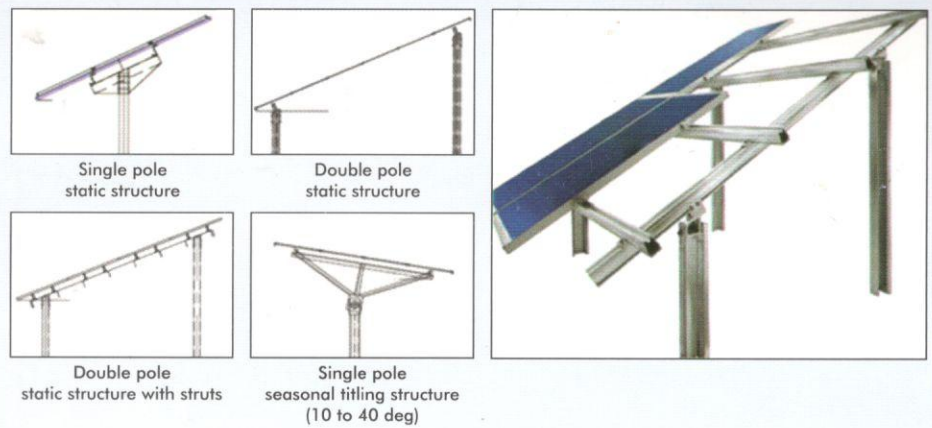

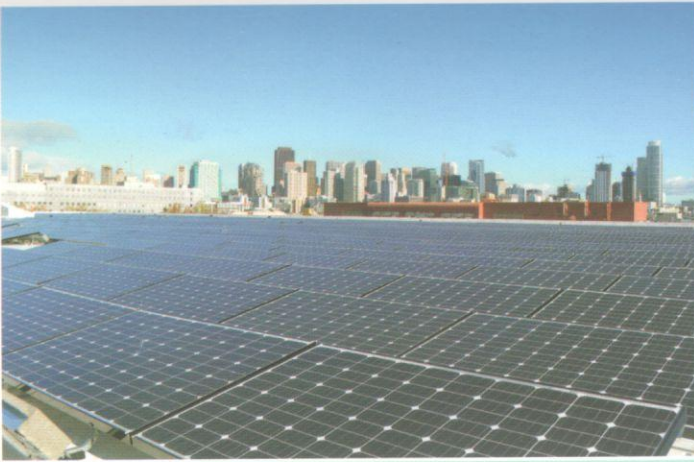

Mfgs. & Exporters of : All Metal Perforated and Expanded Sheets

## PARMAR METALS PVT. LTD.

Reg. Office : 28-A, Bhaktinagar Industrial Estate, Rajkot-360 002. (INDIA)

Tel. : +91 281 2362257 Fax : +91 281 2365252

Factory : Survey No. 207, Veraval (Shapar)-360 024. Dist. : Rajkot.

Tel. : +91 2827 252888